

Shop Safety – Study Guide

©2012 Melior, Inc.

Table of Contents

| | |
|------------------------------------|----|
| INTRODUCTION..... | 3 |
| TECHNICIAN RESPONSIBILITIES | 4 |
| PERSONAL PROTECTIVE EQUIPMENT..... | 6 |
| Eye Protection..... | 6 |
| Hand Protection | 6 |
| Respirators..... | 6 |
| General Precautions | 6 |
| Eye Protection | 6 |
| Hearing Protection..... | 8 |
| Hand Protection..... | 9 |
| Respiratory Protection | 10 |
| Respiratory Operations..... | 11 |
| SAFE WORKPLACE OPERATION..... | 13 |
| Vehicle Safety..... | 13 |
| Ventilation..... | 15 |
| Fire Safety | 16 |
| Material Safety Data Sheets..... | 19 |
| Blood-Borne Pathogens..... | 20 |
| TOOLS AND MACHINERY | 22 |
| Hand Tools | 22 |
| Power Machinery..... | 23 |
| Portable Power Tools | 25 |

| | |
|-----------------------------------|----|
| Power Drills | 26 |
| Bench Grinder | 27 |
| Vehicle Lifting | 28 |
| EPA BEST PRACTICES | 32 |
| Absorbents | 32 |
| Spills Procedure | 32 |
| Smaller Spills | 33 |
| Medium to Large-sized spills..... | 33 |
| Large Spills | 33 |
| Air Conditioning | 34 |
| Catalytic Converters | 34 |
| Automotive Painting..... | 35 |
| Brake Repair / Asbestos | 39 |
| WASTE HANDLING AND DISPOSAL | 42 |
| Hazardous Wastes | 42 |
| Solvents..... | 43 |
| Hardeners..... | 43 |
| Antifreeze | 44 |
| Used Batteries | 45 |
| Used Oil..... | 46 |
| Used Filters | 47 |
| Used Rags..... | 48 |
| Used Tires | 49 |

INTRODUCTION

The productive automotive workplace requires skilled, dedicated technicians devoted to accuracy and safety.

The Occupational Safety and Health Administration (OSHA) is responsible for enforcing safety legislation in the workplace. Similarly, the Environmental Protection Agency (EPA) governs the safe storage, handling, and disposal of chemicals and materials hazardous to the environment. The efficiency and safety of the workplace are dependent upon each technician. Knowledge and understanding of safety procedures and OSHA standards ensures that all technicians work together effectively.

This course will cover workplace protocol and address safety concerns in a range of topics:

- Personal Protective Equipment
- First aid
- Fire
- Power machinery
- Portable power tools
- Air conditioning repair best practice
- Painting best practice
- Sanding best practice
- Chemical storage and disposal
- Hazardous waste
- Workplace debris handling
- Ventilation

Upon completion of this course, technicians should demonstrate thorough understanding of the hazards in an automotive repair facility and how to properly prevent or respond to each situation. While every conceivable danger cannot be realistically addressed in one course, this module will present common issues that technicians will face on a regular basis and will demonstrate how to best handle the situation.

TECHNICIAN RESPONSIBILITIES

Heeding the instructions of both your instructor and posted safety warnings is essential to learning safe, effective workplace protocol. Even the simplest and most familiar tools in the workplace can become dangerous when not handled properly. Hazardous situations arise when safety is not made a top priority.

Students and technicians must be responsible not only for themselves, but also for each other. If another technician is performing irresponsibly or breaking a safety rule, be it intentionally or not, the instructor must be notified. Any instance of injury, however minor, should be reported to the instructor as well. Faulty tools and equipment must be identified and tagged as unsafe. Improper operation makes all tools dangerous.

Posted warning signs should be clear and conspicuous in the shop and should be obeyed at all times—become familiar with them and the symbols they contain.

Warning signs will be predominantly red and indicate an immediate hazard.



Caution signs are predominantly yellow and warn of potential dangers.



Danger signs indicate potentially hazardous situations that could result in serious injury or death.

PERSONAL PROTECTIVE EQUIPMENT

Personal Protective Equipment (PPE) is provided to ensure safety in every task. The most frequent workplace injuries occur because PPE is ignored or worn improperly. It is important to understand maintenance, storage, and proper usage of all your protective equipment.

Different tasks will require specific PPE, so it is mandatory that you know what to use and when to use it.

Eye Protection

Safety goggles must be worn to shield your face from expelled sparks, flames, blinding light, and all chemicals and particles associated with automotive repair machinery.

Hand Protection

Gloves should be worn when handling materials and objects that could injure the hands—hot metal, manifolds, sharp tools, exhaust pipes, and all chemicals—but should not be worn when working with moving machinery.

Respirators

Respirators will be necessary for many tasks in the workplace. However, there are many different respirators designed for different tasks. Using an incorrect respirator may not protect correctly, so learning both how and when to use each model is imperative.

General Precautions

In addition to Personal Protective Equipment, there are some preventative measures you can take to ensure a safer work space. Loose clothing and hair should be tied back and kept away from your work. Dangling jewelry is also a threat to moving parts; these loose articles can catch in moving machinery and cause serious injury.

Rings and metal watchbands should always be removed when working with automotive circuitry; they conduct electricity and cause damage to electrical systems.

Improper lifting and carrying of heavy objects in the workplace can strain and injure back muscles. Bending and lifting with your legs will reduce strain on your lower back and give you control and leverage over your load.

Technicians must wear shoes with oil-resistant soles to prevent slippage on the shop floor; the tops should completely cover feet to prevent injury from falling objects.

Eye Protection

Eye injuries are the most commonly reported injuries in automotive industry workplaces; their severity ranges from minor eye abrasions to complete blindness. It's an astonishing fact, given that preventative eye protection is perhaps the simplest and most compact piece of personal protection equipment.

Safety spectacles are protective eyewear constructed of impact-resistant lenses, often with side shields. Goggles completely cover the eye area, providing maximum protection from dust particles and splashing chemicals. Face shields cover the face entirely with transparent sheets of plastic, but do not prevent impact hazards.



Foreign materials can enter the eye during all types of operations. Debris is the most common eye irritant in the workplace. Material frequently drops from a lifted vehicle or is expelled into the air during grinding tool operations. Blowing tools used for glass shards and dust can blow airborne materials into the eyes.

Engine inspections often yield unexpected airborne particles, chemicals, and hot fluids. Batteries house hydrogen gases and harsh battery acid. Older batteries are prone to exploding, and these acids can spew outward. Because of the proximity of your face to the engine during such operations, the risk of eye injuries increases considerably. Safety glasses and goggles prevent the vast majority of intrusive eye injuries-there is no excuse for not wearing the proper protection.

Welding operations present a different hazard: intense blinding light. Welding shields serve dual purposes of filtering infrared or radiant light and shielding the eyes and face from sparks and metal spatter. Filter shade numbers should be consulted to ensure proper light protection.



All eye protection should be approved for the tasks performed. Technicians should keep their own eyewear with them at all times, and any broken or defective glasses should be immediately replaced. Though safety glasses, goggles, and shields keep most debris out of the eyes, emergency eyewash facilities should be easily accessed from all areas in the workplace.

The most commonly used eye wash facilities are eye wash bowls, which provide continuous water flow. Other available stations have benefits, such as eye wash bottles' portability, but the continuous flow bowls are reliable and ANSI approved. Medical attention is needed for any debris that cannot be flushed by the eye wash facilities. Do not ignore eye injuries.

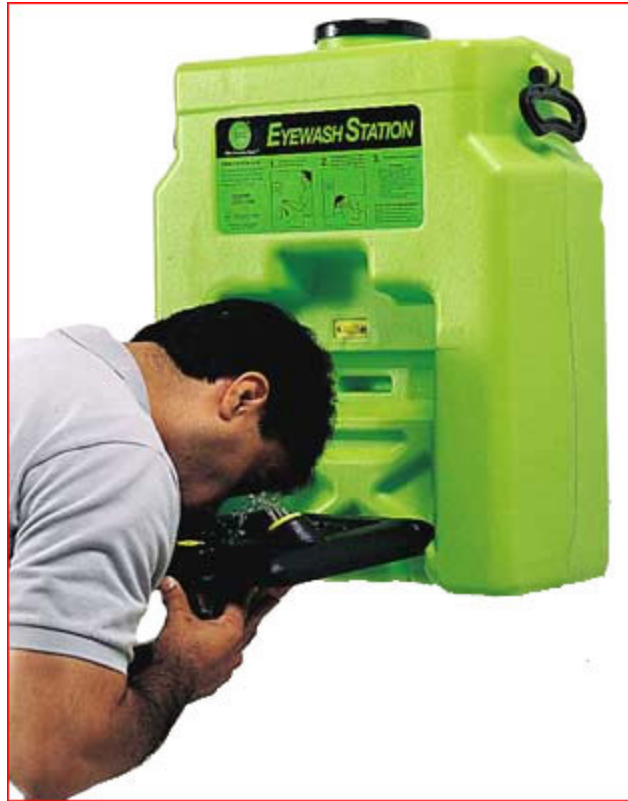

Hearing Protection

Hazardous noise is a serious threat in automotive workplaces. Short-term effects include muffled sound or ringing noises in the ears; prolonged exposure to loud noise may damage the eardrum and cause permanent hearing loss.

OSHA requires that workers exposed to eight hours of noise 85 decibels or higher must be protected by a Hearing Conservation Plan. In the automotive workplace loud machines, like air-pressure tools and drills, often exceed this limit. Though not all tools will have clearly defined decibel output, the National Institute for Occupational Safety and Health (NIOSH) suggests that noise has reached hazardous levels if you must raise your voice in conversation with a person an arm's length away.

The most effective guard against hearing loss is personal protective equipment. In the presence of any high decibel activities, one of the following types of ear protection should be worn:

- Expandable ear plugs are made of condensed foam that can be shaped by rolling the plugs between the fingers into a form suitable to insert into the ear canal. The plug should expand comfortably to stay in place and keep noise muffled. These are generally discarded after each use.

- Pre-molded earplugs are designed to fit into the ear canal without additional shaping. Therefore, these plugs should be fit-tested for each ear—one size may not uniformly fit both ears of a technician. But, because of their consistent shape and material, they may be reused and are relatively cleaner in environments where dust or debris may soil a technician's hands.
- Earmuffs may be fitted to the contours of each technician's individual sizing, and they should be affixed to the technician's head and tightened accordingly. Though earmuffs are effective for some technicians, they may not create a sufficient seal on those with facial hair.



Hand Protection

Hand injuries are among the most common accidents in the automotive workplace. Hands are essential to all tasks and cannot be ignored. Gloves are indispensable protection against all manner of hand injuries, from burns to abrasive cuts, and, like eyewear, are simple protective necessities.



Choosing the right glove for the task is important. PPE is designed to provide a barrier from risks but not compromise your performance as a technician. Obviously, heavy duty material is protective and functional for handling hot or sharp objects, such as sheet metal or exhaust piping. Often these gloves will feature gripping pads in the palm for more tactile handling of materials. Flame resistant gloves are needed for welding operations.

When handling chemicals, solvents, and (in some cases) blood, thin, non-porous gloves are recommended. Similar to surgical gloves, nitrile and latex provide the most reliable protection while still allowing dexterity.

Heavier gloves protect the technician from immediate injury—cuts, burns, and abrasions can be avoided with strong material. Nitrile and latex, however, control chemical exposure, which can

manifest itself in long-term injuries or illness. Remember not to underestimate the effects of a long-term exposure: bandages and stitches might be a pain today, but chemical poisoning can do irreparable damage to your mind and body over time.

It is also important to know when not to wear gloves. Contaminated nitrile gloves should be disposed of immediately after use. Never wear gloves in areas away from your work space. Gloves should not be worn around moving machinery, where they can be caught and pulled inward.

Respiratory Protection

Respiratory hazards are present in many automotive operations, including sanding, grinding, paint mixing and spray painting, brake repair, and solvent handling. OSHA's Respiratory Standard, 29 CFR 1910.134 requires automotive repair facilities to provide respiratory protection to its technicians, and technicians should in turn understand the proper operation and fit of their respirators.

All respirators used in the workplace must be certified by the National Institute for Occupational Safety and Health (NIOSH). All NIOSH and manufacturer standards should be observed when a respirator is in use. In the event of respirator malfunction, the technician must immediately stop performing the task and notify the instructor.

Filters should always correspond to the manufacturer of the respirator. Any damaged or poorly-fitted respirators must be reported to the administrators.

Any situation requiring a respirator calls for a continuous flow SAR (supplied-air respirator) with a loose-fitting hood or a tight-fitting facepiece.

When using a tight-fitting facepiece air respirator, fit testing should be conducted using the actual make, model, and size of the respirator to be used. The testing should be conducted annually and as needed, according to the operator's physical changes. No tight-fitting face pieces should be allowed without prior fit-testing. Facial hair, jewelry, headphones, facial scars, and missing dentures will prevent a secure seal on tight-fitting respirators.



Ultimately, the recommended air respirator is not a tight-fitting facepiece air respirator but a loose-fitting hood supplied-air respirator, as shown to the right. This type of respirator does not require fit-testing and can be worn with a beard.

Respirators should be thoroughly washed and disinfected on a weekly basis. Regular maintenance evaluations should be performed to check for malfunctions in the face piece, head straps, valves,

filters, cartridges, and air supply systems. Technicians are responsible for their own respirators—they should always be stored sealed and out of direct sunlight in clean, dry locations.

Respiratory Operations

There is a variety of respirators available, and they each have specific functions. These cannot be interchanged: they are designed to provide maximum respiratory protection in varying operations.

Negative pressure respirators function by allowing air to move through the respirator through filters and valves. Inhalation pulls air through a filter and exhaling pushes air out through a valve.

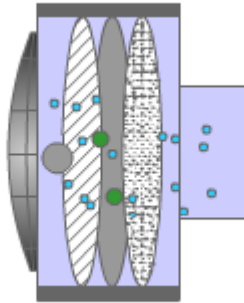

The most common problems on negative pressure respirators are easily corrected by checking filters and valves. Filters should be changed on a regular basis, dependent upon frequency of use. When breathing resistance is noticeable in N95 or N100 models, the filters are likely dusty and should be changed. For organic vapor cartridges, a schedule should be set and adhered to.

Positive pressure respirators import fresh air into the respirator through a hose. Painting operations require this type of respirator most frequently. These respirators are particularly useful for technicians with beards or other facial issues that could compromise a tight seal.



OSHA has identified repair operations that require respirator use. These include:

- Dry sanding requires a half-facepiece APR with N100 (or comparable) filters

- Solvent wipe-down requires a half-facepiece APR with organic vapor filters
- Paint mixing requires half-facepiece APR with organic vapor cartridges
- Spray painting requires continuous flow SAR with a loose-fitting hood or tight-fitting facepiece
- Spray gun cleaning requires a half-facepiece APR with organic vapor cartridges
- Changing spray booth filters requires a half-facepiece APR with N95 filters

SAFE WORKPLACE OPERATION

Clutter, Spills, and General Housekeeping

Practicing safety in the workplace must be constant, concerted effort to understand your surroundings and your equipment. Technicians must have thorough knowledge of chemicals, safe handling of tools and machinery, personal protective equipment for the right job. This knowledge will reduce the hazards and risks of a dangerous environment.

But no amount of experience and skill will prevent slips, falls, and such injuries when the workplace is cluttered, dirty, or unorganized. Most incidents of this sort can be easily prevented. Simple housekeeping routines will help keep the workplace safer and more manageable.

Slips and Falls

Slips are particularly dangerous in an automotive workplace—a customer or technician can fall on the floor, onto machinery, or onto another person. Not only is this a safety issue, but often your shop is legally and financially liable for customer accidents.

Slick floors can be caused by any number of liquids in the shop, from oil to antifreeze to rainwater. In the instance of any liquid on the floor, cleanup efforts should begin immediately.

Drying agents and general housekeeping items should control slick floors and water accumulation. Spill prevention plans should be in place to help control spills of potentially hazardous materials. Slippery areas should have a clearly visible warning sign around them.

Walkways should be cleared of clutter so people can move freely through the shop. Each tool and material in the shop has its proper place, and when not in use, it should be returned there. Your walkways should be designed with safety in mind—handrails should be in place for elevations and stairs, you should have adequate headroom, and be at a safe distance from hazardous procedures. Make sure hoses, cables, and cords are wrapped and stored out of walkways.

Ladders should always be used on dry, non-slippery surfaces. Be aware of the weight capacities of the ladders in your shop. Never climb up or down a ladder facing away from it—your balance will be compromised and you can endanger yourself and those around you.

Vehicle Safety

Safe handling of power tools, machinery, and chemicals is a necessity when working in an automotive facility. It is also important to practice safe operation of another workplace fixture: the vehicle itself.

Technicians working on vehicles will be responsible for the safety of the vehicle as well as their own safety. Often technicians will need to drive a customer's vehicle to move it within the facility, to troubleshoot the problem, or to confirm an operating correction has been successful. All safety precautions should be taken prior to operating a vehicle on the job: check tire inflation, adjust mirrors and seats to accommodate your driving, and wear the seatbelts. As always, never operate a vehicle while impaired by alcohol or drugs.

Working under a vehicle presents a new set of dangers. Vehicles should not be started if workers are already under it. Unless necessary, avoid working beneath a running vehicle. Do not work in direct contact with exhaust fumes under a vehicle.

When a car's brakes do not work, the drive wheels should be blocked and the car should be identified with a caution sign. The vehicle should be in the park position, or in neutral with an engaged parking brake, before starting.



Never leave the vehicle's doors open: when people are working beneath it, they can hit their heads. Open doors will also crowd walkways for passing technicians. Workers beneath a car should keep arms and legs from sticking out to prevent rolling vehicles from running over them. This will also help prevent tripping passing technicians.



A clean driving record is required when working in a transportation-related field. DUI offenses are grounds for termination. Drug and alcohol tests are given regularly to automotive technicians to maintain safe working conditions.

Ventilation

A well-ventilated workspace is essential to safe, effective automotive procedures. Ventilation provides clean, fresh air to enclosed spaces. This is necessary to cleanse the atmosphere of harmful contaminants and improve respiration. Many methods of ventilation are available, from simple windows and fan placement to more complex exhaust and vacuum systems.

General ventilation is a simple method, most commonly achieved through windows and fans. This method dilutes the hazardous concentration with fresh air. This method can only be effective if the hazardous materials concentration is small and unchanging and the air flow sufficiently replenishes the atmosphere. Also, the hazardous material must have low toxicity and flammability levels.

Carbon monoxide inhalation is a common workplace hazard. It is invisible and fills a room from the ground up. Exhaust extraction is necessary when working on a vehicle in an enclosed area. The exhaust extraction unit should be connected prior to starting the vehicle and remain there for the duration of the operation. Carbon monoxide inhalation can cause headaches and nausea, as well as death.



Grinding, sanding, and painting activities are all performed in areas that require proper ventilation.

Painting processes require ventilation. Proper ventilation techniques for these processes will be covered in depth later.

Fire Safety

Fire hazards are common in automotive workplaces due to the prevalence of flammable materials. This means that in the presence of such materials fires are quick to spark and quick to spread in a confined space. Oil, gasoline, solvents, and many compressed gases are all highly flammable.

Material safety data sheets should be available for all chemicals in the workplace; these will explain proper handling. Each chemical's flammability and flash points will be detailed within the MSDS. All technicians should understand how to read and interpret MSDS.

Open flames, flammable chemicals, and sparks all have the potential to start a large fire. Flammable materials should be kept a safe distance from any source of flame, and all areas where they are to be handled must be ventilated to allow gases out of enclosures.

While the fire department should be contacted for large, dangerous fires, fire extinguishers are an important and easily used method of containment. The material that catches fire will have different compositions and should be handled by appropriate extinguishing agents.

Class A fires feature burning embers and most often occur in the presence of paper, wood, or cloth. These fires are best handled by Class A Water Extinguishers.

Class B fires are results of vaporized flammable liquids, greases, and gases and require CO₂ Extinguishers, which remove oxygen to eliminate the flames. Class C fires occur in electrical equipment and cannot be controlled with water extinguishers. CO₂ extinguishers are often used for Class C fires because of their non-conductive qualities.

Dry Chemical extinguishers are capable of controlling multiple classes of fires and are the most common shop extinguisher.



Fire extinguishers should be easily accessible and never more than 50 feet away. They should be mounted between 36 and 60 inches off the floor and be designated by clear, approved signs. Quick access to extinguishers can help control a fire before it spreads. Monthly inspections should be conducted to ensure gauges are full and safety pins are in place.



To use the fire extinguisher, the technician should be standing about eight feet from the fire with the extinguisher hose aimed at the base of the blaze. Pull the pin and squeeze the trigger on the extinguisher. Accuracy is essential because the extinguishing spray will only last around 20 seconds.

Cleared and visible paths to the exits are essential to fire response. Exit strategies and extinguisher operation will help keep you and your shop safer.

Material Safety Data Sheets

"Right to Know" laws are in place to keep employees aware of the hazards in their own workplace. These laws keep businesses in compliance with health and safety legislation and ensure that employees are familiar with hazardous characteristics and proper handling of chemicals.

OSHA requires all employers to provide Material Safety Data Sheets for all hazardous materials technicians encounter. MSDS detail potential dangers and health effects for each chemical and explain safe handling practices. Technicians should understand how to read and interpret MSDS prior to handling chemicals in the workplace.

All Material Safety Data Sheets are required to contain specific information. Some will contain more than is required, but all must meet the minimum requirements. All MSDS will contain the following:

- Chemical identity: the substance as it is identified on the label
- Manufacturer information: the substance's manufacturer name and contact information
- Hazardous ingredients: identifies hazardous contents of the substance, including chemical identity and OSHA's recommended exposure limits
- Physical and Chemical Characteristics: gravity, density, and boiling, evaporation, and melting points
- Fire/Explosion data: flammability and flash points, explosions and extinguishing information
- Reactivity: the chemical's stability, compatibility, and decomposition
- Health hazard data: routes of entry and corresponding health hazards, exposure symptoms, first aid procedures
- Safe handling: handling instructions and spill response, disposal, and storage protocol
- Control Measures: includes respiratory protection and PPE issues
- PEL: Permissible Exposure Limit details the quantity and amount of time you can be exposed to a chemical before it becomes harmful

Some MSDS publications, like the American National Standards Institute (ANSI) have used this OSHA template and expanded their sheets to include additional material handling facts. Your facility will have information on the type of MSDS in place.

The National Fire Protection Association (NFPA) fire diamond indicates a chemical's flammability, health hazards, and instability in color-coded ratings. This and other images often appear in MSDS.



Material safety data sheets will disclose chemical-specific precautions, but there are general workplace precautions you should always remember when handling chemicals:

- Eating, drinking, and smoking around chemicals is prohibited
- Explosive and/or flammable materials must be stored away from heat sources
- Appropriate Personal Protective Equipment must be worn when handling chemicals

Blood-Borne Pathogens

Blood-borne pathogens pose a new kind of threat in the workplace: blood contact has the potential to transmit human immunodeficiency virus (HIV) and hepatitis B (HBV) to technicians. This is not a commonly occurring hazard, but it is one that should be addressed and prepared for.

In addition to the risk of infection from an injured coworker, repairing vehicles that have been involved in an accident exposes the technician to potentially infectious blood and bodily fluids. Being prepared for the various potential threats will reduce your risk.

Treat all blood and bodily fluids as if they are infected. PPE should be worn when handling blood or bodily fluids just as it is worn when handling dangerous machinery. Gloves and glasses will keep blood off of exposed skin. Any blood or fluid that does come in contact with exposed skin should be washed immediately, using hot soapy water.

Blood spills should be attended to immediately, but carefully. Areas with droplets should be wiped at least twice with disinfectant-dampened rags (fresh rags each time).

Larger pools of blood or fluid should be covered by paper towels and concentrated disinfectant. After the disinfectant has mixed completely with the spill (no less than 20 minutes), the paper towels can be discarded properly.

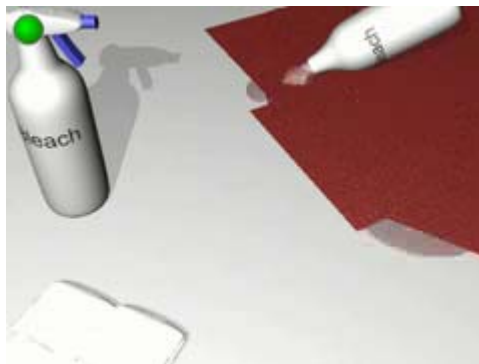

Disinfectants should be in a central location where they are easily accessed. Simple items such as alcohol and chlorine, poured straight from the bottle, can help contain and kill pathogens. Available anywhere, these common household items are an invaluable defense against pathogens in the workplace.

Bleach's corrosive qualities can damage plastic surfaces. If this is a concern, FDA approved sterilants can be used with water.

Contaminated objects should be disposed of in labeled containers. Reusable clothing and work gloves should be labeled and laundered properly. Clothing that cannot be reused should be discarded.

Gloves should always be worn when handling any contaminant. Blood and body fluids are no different. Nitrile gloves (or similar latex or vinyl gloves) are recommended in these situations, and when handling blood-tainted sharp objects, nitrile gloves beneath work gloves offer additional protection. Gloves (turned inside out), metal and glass that have blood residue should be put in plastic bags and disposed of separately from uncontaminated materials.



Copyright Meller, Inc. 2005

PPE should be decontaminated before it is used again. Goggles and face masks will have decontamination procedures that should be followed. Often chlorine bleach or similar disinfectants will be sufficient.

TOOLS AND MACHINERY

Hand Tools

Many of the tools you will use in the shop will be familiar, but they shouldn't be ignored. Improper handling and overloading of a hand tool can cause as much damage as a power tool. The most common hand tool injuries are a result of not using tools for their intended purpose. Using the wrong tool for a job can also wear out the tool, compromising its efficiency.

Technicians' understanding of the hand tool's capacity will reduce the risk of injuries. The tool manufacturer's recommended work load should not be exceeded. Tools that have been overloaded are prone to breaking. Making sure that your hand tools are in safe, working condition will reduce the risk of breakage. Any defective or unsafe tools should be tagged and reported to your supervisors immediately.

Appropriate PPE should be worn when using hand tools. Grinding and cutting procedures will produce airborne debris that can cause eye injuries. Goggles and safety glasses will protect your eyes during these operations.



Regularly cleaning tools will prevent grease, oil, and dirt from accumulating. Tools that are dirty can be slippery and ineffective. Washing your hands regularly will help keep tools in a clean, dry condition.

Tools with sharp edges should be sharpened regularly. Dull tools have slippery edges and require more pressure from the user. Remember to always cut away from your body when using a sharp tool.

Hammers should have a secure handle that fits tightly into the head. The handle should not be split or splintered. Remember that the head of the hammer can chip when struck against a similarly hard surface (i.e. steel).



Split handle on hammer

Files must have a handle; the pointed tang end of the file can easily puncture the skin. The file should be cleaned with a file brush.

Screwdrivers should always be the appropriate size-screwdrivers too large for the job will be unwieldy and dangerous. Make sure the tips match the screwdrivers and there are no chips or signs of wear. Faulty tips do not grip the screw and can jump from the grooves.

Wrenches must be the correct size for the job. Wrenches that are too large for a nut will cause slippage. No other tools should be used in place of a wrench.

Chisels should be kept sharpened to ensure accuracy. Keep your fingers away from the blade's edge. It is important to guide chisels carefully; it is recommended that you use both hands to stabilize the tool against the resistance (unless one hand is needed for a driving mallet).

Some rules seem obvious or elementary, but it is important that you follow them carefully. Carry sharp tools with the sharp edges pointing down. Pass them to your coworkers carefully and with the handle first-never throw or slide tools toward another person. Tools should not be left pointing outward from a work space. This is a hazard for people as they pass by.

Power Machinery

Using hand tools requires knowledge of the tool's capability and the technician's proper handling. In this respect, power tools are no different. They require the same attention and caution. Power tools can be dangerous. If you need to use power tools to work on an object it is best to place the object in a vise. This may apply to normal hand tools as well, especially when working with unwieldy objects or tough materials.

As always, read and understand the manufacturer's instructions prior to operating any power tools in your facility. You are responsible for the tool for the duration that it is on. No other technician should use the tool while it is turned on. Operators of machinery should be aware of all moving parts and not abandon a power tool until it is turned off and all these parts have stopped moving.

Before the tool or machinery is turned on, the area around it must be cleared. Make sure the tool is properly oiled and cleaned. No other technicians should be around the tool—crowding the work area can cause injuries. The machine's "throw" is the direct line out from the tool. Often materials can be pitched or discharged from the tool with great force.

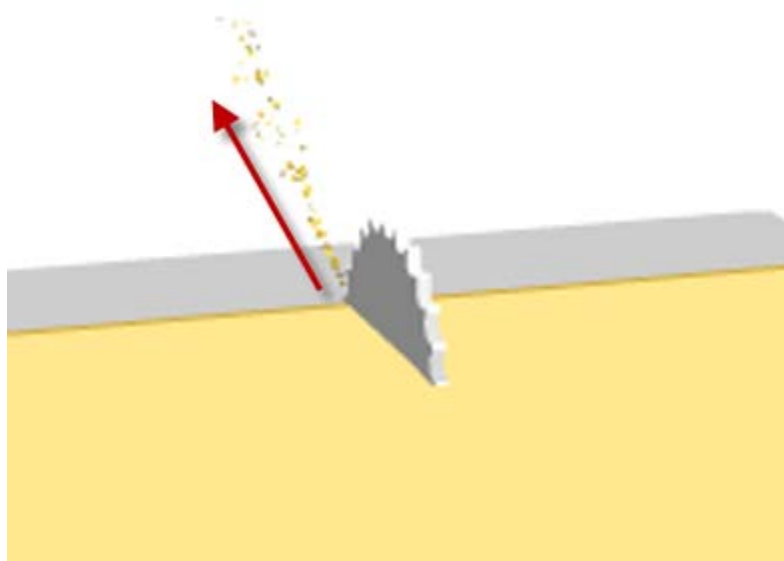

Never use a tool that is missing parts or defective in any way. These should not be turned on until they have been repaired and cleared for operation.

The tool should be cleaned and adjusted before it is turned on. You should wear the proper PPE—usually eye and face protection—whenever you use any power tools.

When the tool is on, the safety guards should be firmly in place.

Make sure that no loose objects are near the machinery's moving parts. Cords should be run as close to floor as possible to prevent tripping. The cord should have no frays or tears in the insulation. Remember to handle electric cords and machinery with dry hands to reduce the risk of electrocution. Avoid using power tools when standing on a wet floor.

A drill press is a powerful tool. When drilling into an object using a drill press it is important to secure the object to the deck or table using strong vise clamps. Reduce the pressure of the drill as it deepens into the object. Using a sharp, grounded drill will reduce the risk of damaging the object or tool.

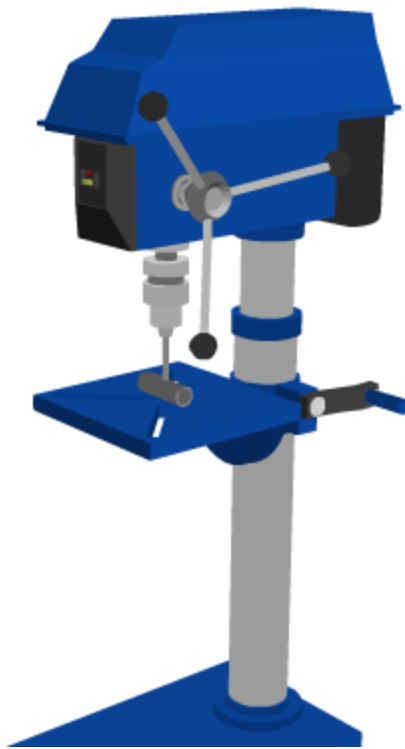

Excessive speeds can destroy the drill—be sure to use the correct speed for the job at hand. Also remember to never remove debris from the drill press while it is turned on.

Face shields are recommended PPE when operating a drill press.

Portable Power Tools

Portable power tools provide mobility and convenience in place of the stationary machinery. These tools do pose dangers, however, and you should observe similar precautions when using them.

Portable power tools use electricity and should always be used carefully. Electric tools should never be used near water or around flammable materials. The risk of fire and electrocution is much greater with portable tools than with stationary machinery, as they are more likely move into volatile areas. Tools with frayed or improperly insulated cords and plugs should not be used.

Power tools should never be carried or yanked by the cord. The strain put on the cord can wear out the insulation and increase the risk of exposed wires, ineffective grounding, and electrocution. When tools are not in use, they should be unplugged. Tools should remain unplugged for cleaning and maintenance.

Regular cord inspection can reduce the risk of shorts and electrocution. Your shop should have short circuit locators or similar equipment for inspections.

Air tools are capable of dispersing harmful airborne debris and should only be operated with proper PPE. Wear safety goggles and respirators as instructed.

All tools working improperly should be tagged as unsafe and reported to the supervisor immediately. Keeping dangerous tools out of the workplace will reduce the risk of injury to you and your coworkers.

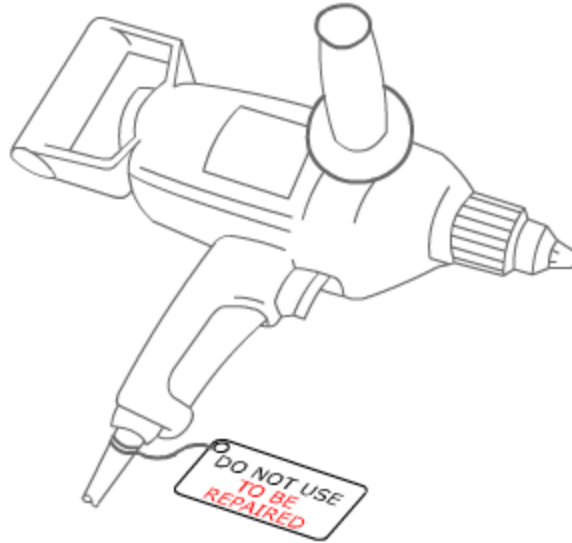

Power Drills

Portable power drills are among the most common power tools you will use in the shop. Specific parts notwithstanding, safe operating procedure for the drill applies to most all power tools. The chuck (or any loose parts) should be tightened before plugging in the drill. Never plug in a drill (or any tool) when it is in the "on" position. The rotation will start immediately and can catch loose materials. No loose clothing, hair, or jewelry should be present near power tools.

Once it is turned on, you need to be able to stop the drill (or any tool) at any time. Keeping a finger on the switch at all times will allow you to control the drill more accurately. Brace a heavy duty drill by holding it with both hands.



Keep all tools away from your body, particularly your face, to ensure you do not injure yourself if you lose control of it. Never hold the material as you drill or work on it.

Damaged or faulty tools should be removed from the work area and labeled with a notice and warning.

Remember to only use power tools for their intended job. Understand what capabilities each tool has and what PPE is required when each is in use. Drilling and grinding tools require eye protection, and air pressure tools may require eye, ear, or respirator protection.

Bench Grinder

Work rests on the grinders should be adjusted to 1/8 inch of the wheel. The tongue guard should be adjusted to within 1/4 inch of the wheel. The side guards should cover 75% of the wheel, as well as the spindle, nut and flange. The wheel's wear should be accommodated by readjusting the tool rest and tongue guards. Vise grips should be used for stabilizing smaller materials to be ground.



Before operating the bench grinder, make sure the grinding wheel is mounted properly. The grinding wheel's revolutions per minute should not exceed the grinder's capacity, and the speed of the grinder should not exceed the operating speed of the wheel.

Never stand in front of the wheel when it is on or starting. The wheel can throw work outward unless it is placed beneath the center of the wheel. It is also important to use the face of the wheel for grinding so that it will not break.

Face shield or goggles should be worn when operating the bench grinder.



Vehicle Lifting

As a technician, you will repeatedly find yourself working underneath a vehicle. Lifting technology enables you to raise the vehicle up, providing the mobility and clearance you need to work. Like all tools and machinery in the shop, lifts and jacks should only be used in accordance with their capacity and function. Using improper lifts and makeshift jacks is a life-threatening risk.

Lifting a full car is best accomplished by a full car lift, but floor jacks and axle stands can do the job as well.



All lifting machinery will have a clearly designated weight capacity. Technicians should learn the capacities of the shop's jacks and lifts. It is important not to exceed these capacities.

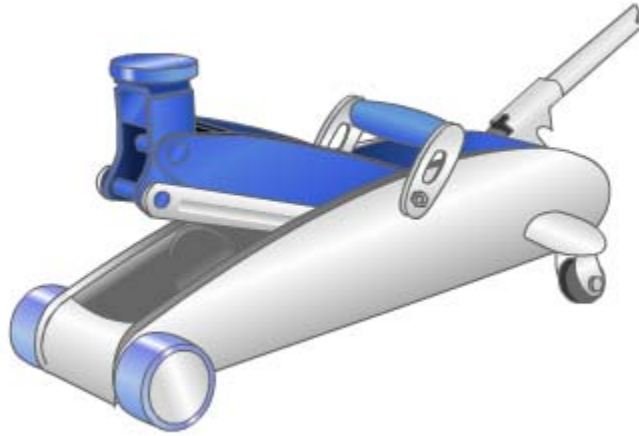

Copyright Meritor, Inc. 2009

Jacks should be in correct working order before using—never use leaking or slipping jacks. Hydraulic jacks should be checked for leaks. Fluid should be maintained at manufacturer's standards.

Never expect a jack alone to hold a vehicle. A jack stand should always be used in conjunction with any jack. This secondary support must be raised to the same height as the jack. The jack handle should be positioned upright when the vehicle is raised. This reduces the risk of other technicians tripping over the handle and releasing the shut-off valve.

Before any vehicle is lifted, its wheels should be secured. Block the wheels opposite the side of the jack. Activating the parking brake will provide additional safety when the vehicle is raised. Lifting jacks should be used only on a level surface.

Vehicles have safe points for jacking—if these are not used, both you and the vehicle are in danger. Aside from the obvious danger of the improperly supported vehicle dropping on you, the jacks can puncture more fragile points on the underside of the car. The jack should never lift at the floor pans, driveshafts, steering arms, or crankshaft pulleys. No jack should come in contact with the axle unless lifting pads are in place. These pads reduce slippage between the axle and the jack.

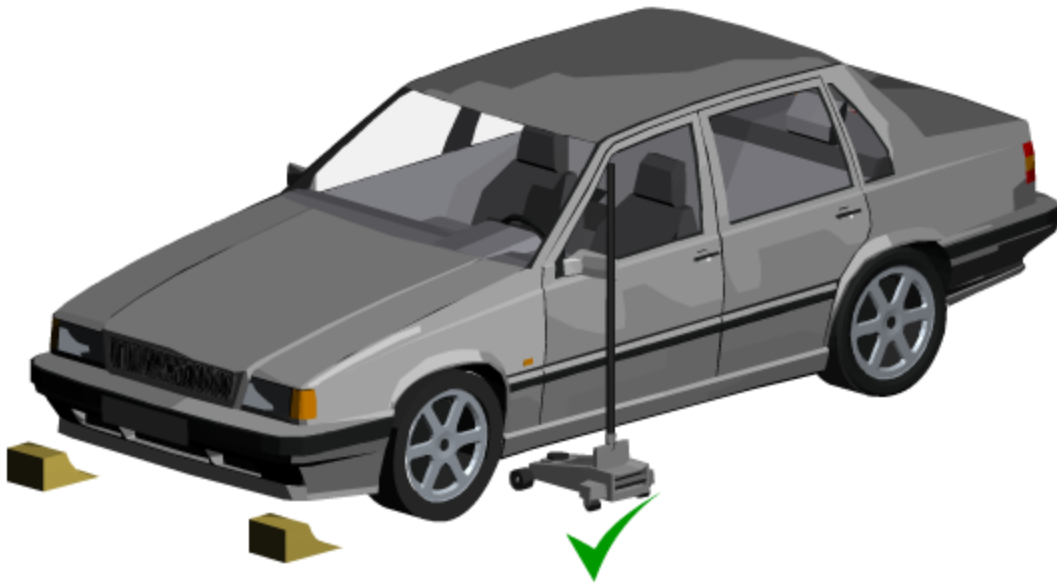

When lifting a vehicle, it is important to follow all safe steps carefully. The weight of a car can cause serious injuries in a fall. When using a jack, remember the following steps:

- Make sure the parking brake is engaged.
- The jack should be situated beneath a secure lift point.

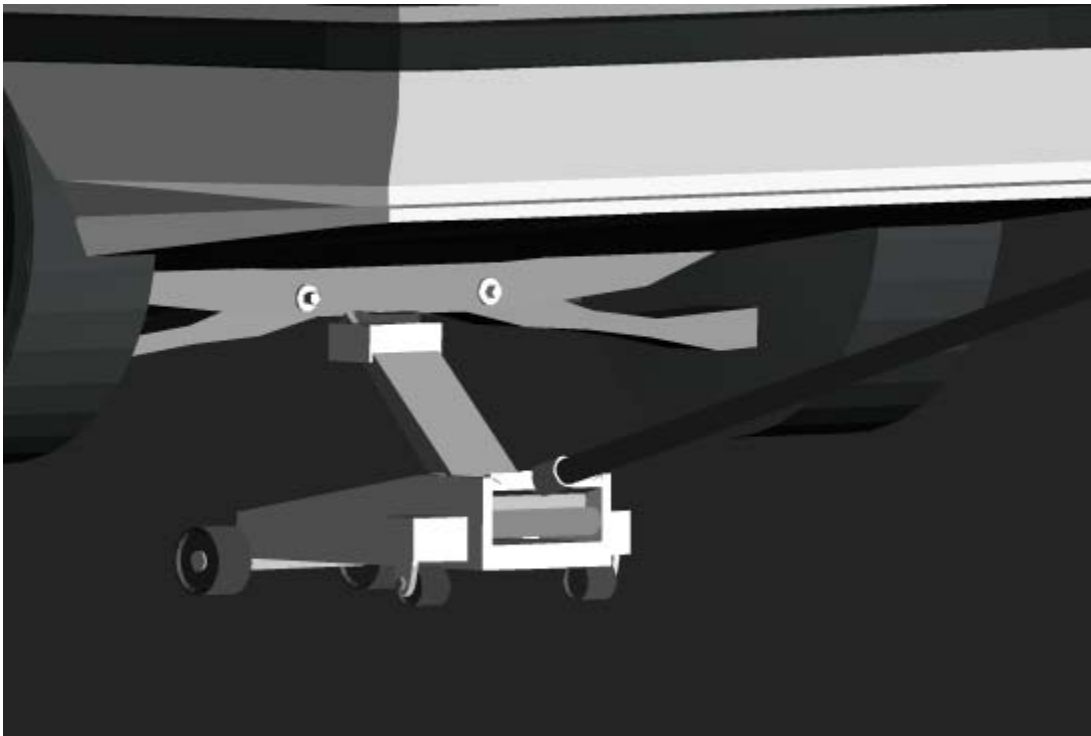

- Jack stands should be put into place to support the weight of the vehicle. Be sure you are familiar with the safe places to lift or stabilize a vehicle.
- After the vehicle is supported on one end, block the wheels on the end opposite the jack. This helps prevent the vehicle from rolling.
- Jack lever should remain in an upright position while the vehicle is raised. This will reduce the risk of passing technicians tripping and releasing the valves.



When raising a vehicle with a complete lift,

- The vehicle should be situated upon the lift with its center of gravity either between the lift pads on the frame contact lifts or near the center of the lift.
- The lift pads should be positioned at the vehicle's designated lift points.
- If the lift has retractable arms, they should be completely extended.
- Block the wheels prior to lifting to ensure the vehicle does not roll.
- Lift slightly to make sure the vehicle is secure and in place. If so, the vehicle can then be lifted completely.

EPA BEST PRACTICES

Absorbents

Absorbents are an essential component of managing spills in the workplace. Wet spills can be dangerous and slippery, as well as contain harmful hazardous chemicals. Absorbents range from sawdust to clay to towels to granular materials, such as rice hulls or kitty litter-type substances. These solid materials absorb wet spills and allow for easier spill management and disposal.

Recycling absorbents is a cost-effective option that will reduce your facility's hazardous waste generator output considerably. Soaked absorbents can be wrung dry of non-hazardous fluids and reused. The absorbed fluid should be stored in properly labeled containers.

Absorbents must be treated as hazardous waste if they have been used to absorb hazardous chemicals. Containers for used absorbents are required in automotive workplaces.

Absorbents used for different chemicals should not be stored together. Each container should be labeled and dated the first time it is used. Older containers are prone to handling damage or reactions to the chemicals stored within. Secondary containment provides additional protection against groundwater and drain leaks. Weekly checks ensure the containers are not corroding.

Your shop's hazardous waste hauler will handle the disposal of used absorbent materials.

Spills Procedure

The foremost concern during a spill is the escape of the material from the shop into the ground outside. Any amount of oil or chemical waste that is released is considered a spill. If your facility allows these chemicals to leak into storm drains or the environment, you can face considerable fines. To contain the spill, block the floor drains with a cover or a temporary dam. Once you have stopped the spreading of the spill, you may then begin the cleanup.



Some spills should be treated as hazardous, such as oil, antifreeze, gasoline, and solvents. Absorbents used for oil spills cannot be placed in landfills. Gasoline and solvents should be cleaned up with a dry absorbent. Remember to dispose of used absorbents in labeled containers.

Spills are also a safety concern in the workplace. Slippery floors cause falls and injuries. Immediate cleanup will reduce the risk of workplace injury as well as prevent environmental contamination.

Smaller Spills

If the spill is minor enough for you to handle, attend to it in a safe manner. Rags (three or less constitute a "small" spill) should be used to absorb these materials. Used rags should be wrung out into appropriately marked containers and stored for cleaning or recycling. Remember the procedures we discussed for rag laundering and recycling.

Medium to Large-sized spills

Spills that require more than three rags to wipe up should be controlled with different tools. Mops are a readily available means of spill cleanup, but different spills will require different mops for complete absorption.

When using a mop for such a spill, it is important to keep the spill contained. Typical side-to-side mop motions will spread a spill; consequently you have a larger area to control and clean. Instead use dabbing motions within the perimeter of the spill. By dabbing, you are pulling the spill into the absorbent mop. The spill in the mop should then be disposed of properly before you resume the dabbing.

Oil spills require a mop known as "hydrophobic". As the name states, this mop prohibits the absorption of water and allows for oil absorption only. Using the dabbing technique, you can soak up spilled oil and dispose of it safely.



Antifreeze spills can also be controlled by a mop, but a hydrophobic mop will resist its absorption. Instead use a dedicated cloth mop (a cloth mop used only for antifreeze cleanup).

Rags may be used after mopping to dry the floor, but they should not be saturated (dripping rags will re-contaminate the area). Launder or dispose of them afterwards according to your shop practice.

A wet mop may be used with caustic detergent only if necessary. Local sewage and water works should be contacted prior to emptying the cleanup water into sinks or drains.

Large Spills

Large spills must be contained as quickly and safely as possible. When a large spill occurs, it is important to notify your coworkers immediately. The spill must be assessed and handled accordingly. If the material spilled is flammable, fire extinguishers should be on hand.

The National Response Center handles major spills and accidents; they should be notified if the spill is larger than 12 gallons or 100 pounds. Local emergency response services (like the Fire

Department) should be able to help control the spill, but the EPA must be notified of any environmental violations.

Air Conditioning

Since the early 1990s, the Environmental Protection Agency has monitored and regulated the handling of ozone-depleting substances. Specifically, the 1990 Clean Air Act limited the emissions of such substances from motor vehicle air conditioners (MVACs).

Chlorofluorocarbons (CFCs) are common in the automotive industry—they appear in solvents, fire retardants, and refrigerants. Freon R-12 was used in MVACs until the mid 1990s, when the Clean Air Act ceased its production in favor of the more environmentally friendly R-134a. This refrigerant has a much shorter life span in the atmosphere and approximately 2 to 12 percent of the ozone depleting potential of CFCs, which for years had chemically distressed the ozone layer.

Prior to MVAC repair, the unit must be emptied of all refrigerant using approved recovery/recycling equipment. Release of CFCs into the atmosphere is illegal and can earn you and your shop hefty penalties. Freon exposure can have severe health consequences, from nausea and dizziness to blindness and paralysis. Wear appropriate PPE to reduce exposure.

The EPA has approved equipment for recovery and recycling of MVACs in conjunction with the Society of Automotive Engineers' approval standards. The EPA publishes a list approved refrigerant reclaimers for MVACs; technicians should see to it that only approved machinery and reclaimers are employed when handling refrigerant. There is no single national standard for antifreeze recycling, so your shop should have methods in place that meet your local agencies' requirements.

Technicians must be certified in the EPA's Clean Air Act Section 609, which details approved equipment and handling procedures. Certification should be carried or available at the shop when working on MVAC systems.

Alternate refrigerants may be used if they comply with the EPA's Significant New Alternatives Policy (SNAP). Alternatives are studied for their environmental ozone threats and possible toxicity characteristics. Your shop should consult the EPA's regularly updated list of approved alternatives.

Catalytic Converters

Catalytic converters reduce emissions from vehicle's tailpipes and must not be removed prior to their warranty expiration date.



Catalytic converters installed in vehicles prior to 1995 are under manufacturer's warranty for five years or 50,000 miles. Since then, catalytic converters have been installed with eight year / 80,000 mile warranties. Technicians should not install aftermarket catalytic converters before the warranty expires.

Replaced catalytic converters should be kept onsite for at least 15 days, labeled with information on the car from which it was removed. Dated work orders can be attached to the converter. Catalytic converters are easily recycled for their metals.

The facility should retain completed paperwork on the installation for at least six months. This paperwork should include the work order and customer invoice, including the customer's name, address, the vehicle's make, model, and mileage, and reasons the catalytic converter was replaced.

Automotive Painting

Automotive painting should be done in appropriate areas of the facility. These areas should have no drains in the floor.

Typically, old paint is removed in preparation for new paint jobs. Grinding, sanding, and grit blasting are effective means of stripping the vehicle bodies for repainting. These processes should be conducted in a booth designed for dust and debris collection. Exposure to the dust and debris from these processes exceeds OSHA's permissible heavy metal limits. Likewise, these operations cannot be conducted outdoors because debris will disperse into the environment.

Debris from any paint sanding or stripping operations will be considered hazardous waste if the paint contained lead or chromium. The Toxicity Characteristic Leaching Procedure will test this debris for hazard levels.

Different sanding procedures require different PPE. Dry sanding requires a half-mask air purifying respirator with N95 particulate filter or better. The area should be well ventilated and have a vacuum sanding system in operation. Wet sanding requires at least protective gloves.

MSDS sheets and paint labels should indicate the volatile organic compounds (VOCs) content of the paints used. Many areas have VOC restrictions; local authorities will determine this for your shop.

When preparing paint for a job, mix only the amount needed using a computerized mixing system. Calculating the amount of paint to be used will reduce leftover quantities. The paint should be mixed in an area designed with adequate ventilation. Emission sources must be near exhaust vents. All containers should remain closed when not in use. Gasket-sealed, spring-loaded covers for solvents and waste storage will keep emissions down. Remaining mixed paints can be stored for future use. Stored paints should be labeled in proper containers.

No spent paint products should be disposed of on site. Hazardous characteristics may exist, and as such, should be properly transferred to off-site disposal. Spray booth air filters should be disposed according to their hazard characteristics. The filters that qualify as non-hazardous can be disposed of in a municipal landfill, while those that show hazardous qualifications should be handled as hazardous waste.

Half-mask air purifying respirators with organic vapor cartridges should be worn when mixing paints. Nitrile gloves and protective eyewear should also be worn as well.



Efforts should be made to minimize the amount of paint dispersed into the atmosphere, known as overspray. High-volume, low pressure spray guns (referred to as HVLP) increase the transfer efficiency of the paint while eliminating excess overspray. This benefits the painting technician by reducing his or her exposure, and is a more cost effective option for the facility. Less paint wasted means lower paint expense.



Mastering proper HVLP techniques will improve the spray gun's effectiveness. Large diameter air hoses and full capacity compressors will ensure that sufficient air pressure is delivered. Each spray gun should be set up to ensure the proper pressure at the gun's tip. Choose the correct tip for the job and use proper spraying techniques.

When spray painting, be sure to wear appropriate PPE, including a loose-fitting supplied-air respirator (APF of at least 25), nitrile (chemical-resistant) gloves, and protective eyewear. Coveralls and headsocks should be worn to cover clothing and exposed skin.

Keeping the spray gun in clean, working order will improve its effectiveness. After usage, the gun should be pre-cleaned to remove contamination. Then an automatic gun cleaning unit can be utilized. The same PPE worn for spray painting should be worn during cleaning, though an organic vapor cartridge should be used in place of the APF.

The EPA recommends the following procedures for paint mixing:

- **Keep Containers Covered:** Covered containers will keep the fumes and vapors out of the air and reduce evaporation of materials. Gasket seals and spring-loaded covers should be used for solvents and wastes.
- **Ventilation:** All vapor-generating materials and equipment should be located in front of exhaust outlets. Exhaust outlets will pull these vapors from the work areas and out of the room. Exhaust hoods behind the mixing table are recommended. Position all mixing equipment near exhaust points.
- **Air-Purifying Respirators:** Air purifying respirators with organic vapor cartridges are necessary when working in the mixing room (this is the minimum safety requirement; a supplied-air respirator is more than adequate). Organic vapor cartridges should be regularly checked and changed to provide adequate protection.
- **Gloves and Protective Clothing:** Chemical-resistant gloves (Nitrile or Butyl Rubber) should be worn to prevent skin exposure. Latex gloves do not provide protection against solvent exposure. It is important to use gloves that are not old, punctured, or torn. Paint mixing suits should be available for this operation. Isocyanates are the leading cause of occupational asthma. Tactile contact with solvents or hardeners containing this compound can trigger these reactions.
- **Eye Protection:** When wearing a half-mask APR, safety goggles should also be worn. Full face shields are also an option. Both of these eliminate chemicals' contact with your eyes and face.

- Reduce Waste: Mixing only the amount of paint and coatings needed for a job will lower the costs of both the refinishing and the waste disposal. Computer mixing is an accurate means of determining the amount of coating for a job, as well as for labeling excess paint for future use.
- HVLP: High-volume, low-pressure spray guns should be used to reduce overspray. These spray guns are the most accurate and efficient tool for painting. Reducing overspray reduces the amount of paint needed.
- Reuse: Leftover primers and basecoats can be reused if stored properly. The cans of used paint can be closed and stored.
- Automated Gun Cleaner: These cleaners allow you to use solvent efficiently. Waste is reduced and contact with hazardous material is minimized. Gun cleaners may be equipped with exhaust fans that capture vapors prior to their release; such cleaners should be connected to adequate exhaust outlets in the mixing room. Pre-cleaning the gun of gross contamination will improve the efficiency and longevity of spray guns and cleaning solvents.

Safety procedures for spray painting are similar to those taken when mixing paint. In both operations, proper PPE must be worn at all times. Effective ventilation is necessary to keep fumes from staying in the atmosphere. The EPA recommends the following steps be taken to ensure the safest spray painting operation:

- Spray booths or vented prep stations should be well-ventilated, most commonly by down-draft (though semi-draft and cross-draft options are acceptable). Make sure the ventilation system is working properly before operation.
- Respiratory Protection: A loose-fitting hood supplied-air respirator (SAR) or better (APF of at least 25) should be used during all spray painting operations.
- Hand protection: Gloves reduce skin exposure to harmful irritants, including solvents and paint materials. Nitrile or butyl rubber gloves are recommended; latex gloves will not protect the skin from exposure. Be sure there are no rips or tears in the gloves.
- Protective clothing: Coveralls, headsocks (if not using hooded respirator), and/or full body suits will help prevent spray painters from contaminating the clothes they wear home. These can be laundered on site after the painting operations are finished.
- Eye protection: Goggles are necessary when not using a hooded respirator. Hooded respirators will cover the eyes, but half-mask respirators will leave the eyes exposed to airborne irritants.



Spray gun cleaning should be performed after each use to maintain the gun's effectiveness and accuracy. The EPA recommends the following steps be taken in Spray Gun Cleaning Best Practices:

- Automated Gun Cleaning units should be utilized to reduce skin and lung exposure to paints and cleaning solvents. The cleaning unit should be regularly checked to ensure hoses and lids are properly attached and sealed. It is recommended that the cleaning solvent be replaced at least once monthly.
- Respiratory Protection: Half-mask APR with organic vapor cartridge or better should be used during the cleaning process.
- Protective glasses and chemical-resistant gloves should be worn to reduce exposure.



Brake Repair / Asbestos

Asbestos has been used in the automotive industry for years because of its nonflammable, seemingly indestructible design. Tiny fibers provide a resilient surface for friction-based moving parts, like clutches and brake linings. Asbestos can handle the high temperatures friction produces without burning; instead it wears slowly and visibly, in the form of dark dust. The dust produced by worn asbestos can pose dangerous risks if it becomes airborne. Cancer and the lung condition mesothelioma have been attributed to prolonged asbestos inhalation.



By its nature, asbestos dust can easily disperse into the air, even during minor, seemingly safe procedures. Asbestos dust is prone to scattering during attempts at cleanup. Wet rags and solvents will contain the dust momentarily, but the fibers will loosen and float again as the rag or solvent dries.

Some precautions to reduce the risk of asbestos inhalation:

- Using hand tools in place of air or power tools will reduce the air displacement
- Never blow asbestos dust from a surface
- Use a High Efficiency Particulate Air filtration to ventilate area of dust
- Wear approved respirators and PPE

Solvents used in brake repair will likely require hazardous waste handling, but the asbestos count is not to blame. Flammable characteristics will deem such solvents hazardous.

Brake pads containing asbestos should be recycled or reclaimed if possible. Companies that will recycle or reclaim these pads should be notified of the asbestos presence. Only landfills and disposal sites that are approved for asbestos should be used if you are not recycling or reclaiming the pads.

Asbestos-containing brake pads must be in sealed, labeled containers (name and location of the waste generator) if they are to be disposed of in EPA-approved landfills. Vehicles transporting the asbestos must also be clearly labeled during loading and unloading. Make sure all shipment records are accurately maintained.

When washing brakes, it is important to keep asbestos dust contained. Wet brake washers are often portable and can prevent dust from dispersing into the air. Dry brake cleaning equipment is designed to cover the brake in a sealed enclosure while a vacuum air system removes the dust.

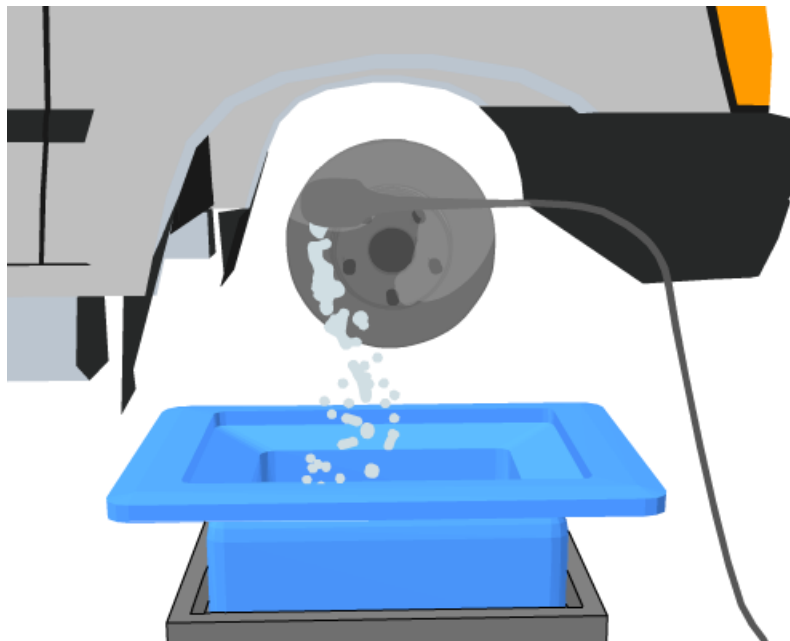

High Efficiency Particulate Air filtration systems are the most effective vacuums for asbestos dust removal; their filters capture the microscopic fibers. The HEPA is used often in dry type brake

cleaning. In this process, the brakes are enclosed in sealed equipment and dust is removed through the vacuum.

HEPA vacuum filters must be disposed of as hazardous waste; they should be sealed in leak-free wrapping. The filters should be labeled as asbestos and warn of its health effects.

Repairing clutches puts technicians in direct contact with asbestos dust because they must be underneath the clutch to reach it. The technician should wear all appropriate PPE (goggles, respirator) when under the clutch.

Clothes worn during asbestos exposure should be laundered immediately. Some automotive shops offer on-site laundering service. No technician should leave work without washing hands, face, and changing clothes.

WASTE HANDLING AND DISPOSAL

Hazardous Wastes

Hazardous wastes are discarded materials defined by the Environmental Protection Agency as “solid waste,” including solids, semisolids, liquids, or contained gaseous materials. Listed wastes and characteristic wastes are regulated under the Resource Conservation and Recovery Act (RCRA).

Listed wastes are known to have harmful effects on humans and the environment when managed improperly, regardless of their concentrations.

Spent cleaning solvents often contain listed wastes. Chlorinated compounds in spent halogenated solvents qualify as listed wastes, as do xylene, methanol, ethyl ether and methyl isobutyl ketone in spent non-halogenated solvents.

Some waste is not classified as a listed waste but is still considered hazardous. These wastes are identified by their hazardous characteristics:



- Ignitable wastes, including used paints, degreasers, oils, and solvents, are flammable or prone to spontaneous combustion. Ignitable wastes have a flashpoint of less than 140° F.



- Corrosive wastes are capable of corroding metal storage, like tanks, drums, and barrels. Acids and bases with pH less than 2 or greater than 12.5 fall into this category; they are present in battery acid, rust removers, and many workplace cleaning fluids.



- Reactive wastes, like lithium-sulfide batteries and explosives, are unstable and are prone to explode or produce toxic vapors and fumes when mixed with water.



- Toxic chemicals have high concentrations of heavy metals and are often fatal when ingested or absorbed.

Acutely hazardous wastes are classified as hazardous regardless of proper management. These wastes, which include pesticides, are so hazardous that any exposure can be life-threatening.

Many operations in the automotive workplace will generate waste. All wastes not recognized as a listed hazardous waste should be evaluated for hazardous characteristics. Consulting the MSDS for products involved in each operation will often reveal the characteristics to help you determine its status.

Solvents

Solvents are liquids that can dissolve other substances. Repair facilities rely on solvents for many tasks, most commonly for equipment or parts cleaning. Halogenated solvents are common in automotive repair shops, especially methylene chloride, trichloroethylene, and 1,1,1-trichloroethane. When using any halogenated solvents, operators must submit a notification report to local air quality authorities. National Emissions Standard for Hazardous Air Pollutants (NESHAP) standards require that a facility declare their solvent cleaning machines and an estimate on annual solvent usage.

Solvents can be stored in compatible containers with a lid and kept closed. The container should be labeled clearly for storage or transport. Solvent containers should be checked weekly for leaks.

Technicians using solvents should wear appropriate PPE and do so in a well ventilated area. Half-mask air-purifying respirators with organic vapor cartridges are recommended, as well as chemical-resistant gloves. Solvents contain highly toxic liquids that pose a threat to both you and the environment. Common solvents in the auto shop include:

- Toluene is a volatile organic solvent and a hazardous air pollutant used in automotive paints and thinners. Extended exposure to toluene can damage the nervous system and kidneys, and high level exposure in a short time can cause memory loss, nausea, weakness, unconsciousness, and death, among other things.
- Ethyl benzene exposure can cause similar complications, though less is known about its long term effects. Headache, eye and skin irritation, potential coma, and death are related effects. This chemical is used frequently in paint manufacturing and spray painting operations.
- Other chemicals have shown to cause occupational asthma, nerve damage, and cancer.

Automotive repair shops should dispose of their spent solvents according to the EPA's waste regulations. Spent solvents should never be emptied into drains or dumpsters. If the facility does not contract an outside handler of spent solvents, it must determine if the solvents are hazardous. Licensed recyclers and disposal companies should handle the solvents once you have properly stored and labeled them.

Sludge generated from solvents used in parts cleaning may also be hazardous. If the sludge is determined to be hazardous, it must be handled in accordance.

Hardeners

Diisocyanates are molecular compounds of two or more isocyanate groups. Most commonly found in hardeners and polyurethanes, these coatings have high mechanical resistance and are resistant to chemicals and weather. Because of their versatility and performance, they are commonly used in automotive painting procedures.

Technicians responsible for painting and sanding operations will have the most direct contact with diisocyanates. Exposure to diisocyanates has been shown to cause skin irritation, respiratory

sensitization, and may cause cancer. Sensitization is a condition that makes workers prone to asthmatic reactions with even minimal exposure, and diisocyanates are the leading cause of occupational asthma.

Diisocyanates should be handled in isolation when possible. If machinery allows for operators to avoid contact with isocyanates, it should be used. Closed system or exhaust ventilation are recommended to reduce harmful isocyanate particles in the air. HVLP spray guns and down-draft spray booths are effective means of lowering diisocyanate exposure.

NIOSH-approved respirators should be worn whenever handling these chemicals. Other PPE recommended to reduce skin exposure include safety goggles and chemical-resistant gloves.

Workers who come into contact with isocyanate contacts should observe rigorous decontamination procedures. Soap and clean water should be used on skin, while exposed eyes should be flushed with clean water. All clothing should be laundered completely before it is used again.

Antifreeze

While new antifreeze is not classified as a hazardous waste, used antifreeze often contains high levels of heavy metals. Engine remnants of lead, cadmium, chrome, and benzene often appear in used antifreeze, and these qualify as hazardous waste. Though testing may indicate no metals are present in used antifreeze, it is quicker, safer, and more economical to treat all used antifreeze as hazardous.

Because we are treating used antifreeze as a hazardous waste, it must be disposed of as such. It is illegal to pour antifreeze outdoors or into plumbing and septic systems. Used antifreeze should be stored by itself in tight, leak-free containers. Labels should indicate its antifreeze contents to distinguish it from used oil storage. Often there are standards limiting the amount of antifreeze a facility can store, however, so check with local agencies before storing.



Whenever possible, used antifreeze should be recycled. Recycling is the most cost-efficient and environmentally safe way to handle used antifreeze.

Reclaiming is the preferred method of antifreeze recycling. Piping extracts the used antifreeze and filters it through a Closed Loop System; afterward it is returned to the radiators. The antifreeze may still be hazardous, but because it is returned to its original use, is not considered a hazardous waste. The non-closed system removes the used antifreeze to a drum, where it should be stored according to hazardous waste regulations.

Used Batteries

Because used batteries contain lead battery acid (toxic) and sulfuric acid (corrosive), they are classified as hazardous waste. Used batteries should be recycled. Your workplace should have an active battery recycle program. Improper disposal of used batteries is a violation of EPA law.

Recycling used lead acid batteries also helps reduce your shop's hazardous waste generator status—the weight of a few batteries can reclassify a facility as a large quantity hazardous waste generator.

When handling spent batteries, it is important to take several precautions. Remember, lead battery acid is a hazardous material. Often batteries are leaking or have been cracked or broken. These should be neutralized immediately: upon removal they should be stored in an acid-resistant tank and submersed in baking soda or vendor-supplied neutralizing agents.

Tips for safe handling and disposal of batteries:

- Technicians should always wear safety glasses and acid resistant gloves to protect from possible explosions or acid leaks
- Batteries should only be stored on acid-resistant shelves and should never be stacked atop each other. Cracked or broken batteries can leak and drip acid.
- Wooden pallets may be used only if they are placed on impermeable surfaces.
- Do not store batteries near inside drains or exterior storm drains.
- Damaged batteries should be stored in a leak-free tub to ensure no leaking acid is released. The tub should be acid-resistant and should be stored in a covered, secure location.
- Secondary containment is necessary to prevent battery acid from contaminating soil or water.



Other means of recycling will involve contracted services that can legally remove and transport the used antifreeze. If these methods are used, your facility should have protocol in place for reference.

Used Oil

Used oil is responsible for widespread pollution and environmental hazards. It spreads easily and is quick to contaminate large amounts of water and soil. While not typically classified as hazardous, used oil should always be recycled or reclaimed according to state requirements.

The Used Oil Standards regulate the recycling, disposal, and storage of used oil. These standards are not limited to spent motor oil; any petroleum based oil or synthetic oil is considered oil, including transmission fluids and lubricants.

Oils are contaminated in the vehicle by engine metals, water, dirt, and chemicals that can render the oil hazardous. Oil can be recycled, however, and then will not be subject to hazard waste regulations. When it is stored, used oil should be clearly labeled in a leak-free container. Used oil should not be mixed with hazardous materials.

Oil can be reused many times, so recycling the used oil is both environmentally sound and financially beneficial. Some facilities choose to recondition their oil on-site, which will rid the oil of its impurities. If the facility re-refines its oil, it can be used as base stock for lubricating oil.

Used oil can also be burned as a method of energy recovery. After the water has been removed, used oil can be burned to fuel space heaters. Consult with regulatory agencies to ensure no harmful air emissions result from the burning.

Whenever oil is handled, there are common standards developed by the EPA that should be observed, regardless of process, quantity, or hazard characteristics of the oil. These include:

- Keeping all oil storage containers in good condition, without leaks or signs of wear
- Storing all used oil containers on flat, impenetrable surfaces (asphalt or cement) to prevent oil from spreading or seeping into the ground
- Labeling all containers and storage with clear, visible "used oil" signs
- Shipping used oil to any offsite location requires transporters with EPA identification numbers

Storing used oil is no different from storing hazardous materials in the workplace—it should be stored in labeled containers separate from hazardous waste. Once used oil has been stored with hazardous waste it can no longer be recycled and must be disposed of as hazardous waste.

Used Filters

Used oil filters can be terne-plated or non-terne-plated. Terne-plated filters contain lead and tin; therefore they must always be treated as hazardous waste. Used oil filters that are not terne-plated will be exempt from federal hazardous waste requirements if they are properly drained. Hot draining is the preferred means of removing residual oil, and filters that have been hot-drained can be disposed of as solid waste.

Hot-draining involves removing the filter from a warm engine and immediately draining it. Acceptable methods of hot draining:

- Gravity Draining: the filter should be removed and placed gasket side down in the drain pan. Puncture the filter and its anti-drain valve. The filter should drain until it is empty for 12 to 24 hours at a minimum of 60 degrees.

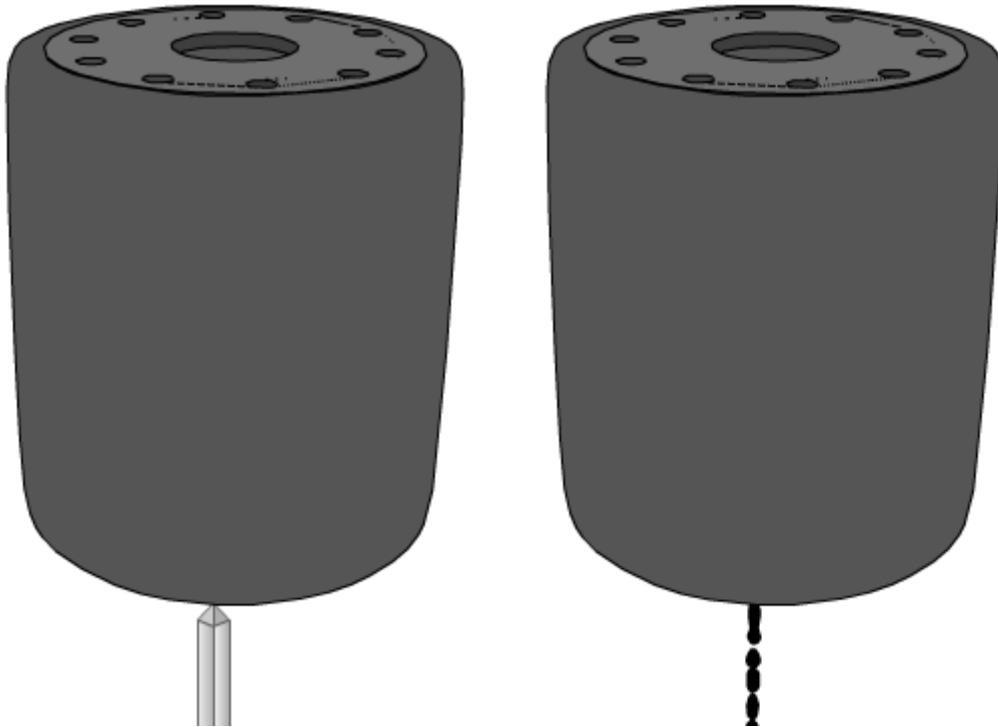

- Crushing: the filter can be crushed to squeeze out used oil prior to recycling.



- Disassembly: the filter should be disassembled and each separate part allowed to drain. The filter's parts can be recycled separately.
- Air Pressure: oil can be removed from a filter by an air pressure device.

All drained oil should be stored and clearly labeled. Usually, used oil can be stored with other oils for recycling (transmission oils, synthetic oils, petroleum-based oils and lubricating fluids). Used oil should never be mixed with hazardous materials; this will render the entire container hazardous. Gasoline, paints and paint thinners, antifreeze, wastewater, and wastes of unknown origins should be stored separately and handled as hazardous. Used filters should be recycled by scrap recyclers or disposed of in solid waste landfills.

Gravity-draining will also clear spent transmission filters and fuel filters of hazardous waste characteristics. These, too, can be disposed of as solid waste.

Filters from antifreeze recycling units may be considered hazardous waste. Testing the filters for metals will determine their hazardous status. If they prove to be hazardous waste, antifreeze filters must be disposed of as such. Non-hazardous antifreeze filters can be disposed of as solid waste.

Used Rags

Towels and rags are subject to hazardous waste standards if they have been used with gasoline or antifreeze, or if they demonstrate hazardous characteristics such as ignitability or toxicity. If so, they can be washed by a professional laundry service or can be disposed of at approved facilities.

Professional laundering services will have guidelines for contaminant and volume intake.

Storing oily rags in airtight metal containers will reduce the risk of spontaneous combustion, which occurs when oxygen raises the internal temperature of something to its ignition point.

Rags that are reusable should be handled in an environmentally safe manner as well:

- Soaked rags should have their fluid wrung out into proper containers; no dripping rags should be stored.
- Used dry rags should be stored in approved containers clearly labeled for “used solvent rags only.”
- Do not store rags used with different solvents in the same container
- Do not store rags with any other waste
- Rags should not be disposed of in landfills.

Used rags contaminated with oil can often be burned, under the Used Oil Management Standards, as an energy recovery method. Until the oil is removed from such rags, they should be handled like used oil. EPA standards dictate that used oil has been efficiently removed when it no longer flows freely from wrung rags.



Used Tires

While not classified as hazardous waste, used tires pose harmful environment consequences if not properly disposed.

Pests and rodents are prone to live in stacks or piles of dumped tires. Mosquitoes breed in water collected in dumped or stacked tires, and the threat of mosquito-transmitted viruses, like West Nile, has become increasingly stronger.



Burning tires pose the greatest threat. Used tires stored in piles or stacks are very hard to extinguish. As they burn, the tires emit petroleum clouds into the atmosphere and deposit contaminated oil into the earth. The soil and groundwater contamination will require extensive remediation.

Water will not extinguish a tire fire. Wetting adjacent tires to prevent them from igniting is useful, but to control the fire itself, sand or dirt should be poured on top. Smothering the fire is the most effective means of extinguishing the blaze.

